

# 2040PiPlus **HIGH-OUTPUT** ASSEMBLY and OPERATING INSTRUCTIONS

# EarthWay<sup>®</sup> HIGH-OUTPUT

Congratulations on the purchase of this new EarthWay spreader. Please call us if you have any difficulty with assembly or operation of this spreader. We can be reached via the telephone at 800-294-0671 or 574-848-7491 Monday—Friday 9:00am ~ 4:00pm or visit us online at [www.earthway.com](http://www.earthway.com) This spreader comes with lifetime technical support, email us at [techsupport@earthway.com](mailto:techsupport@earthway.com).

## **HELPFUL HINTS: READ THE DIRECTIONS BEFORE ASSEMBLY**

THIS SPREADER COMES PARTIALLY ASSEMBLED, REQUIRING YOU TO INSTALL THE CONTROL ROD AND WILL REQUIRE 1 PAIR OF PLIERS.

- ☑ Your spreader is designed to be pushed at three miles per hour, which is a brisk walking speed. Slower or faster speeds will change the spread patterns.
- ☑ Clean your spreader thoroughly after each use. Wash with clean water and dry thoroughly and spray a light coating of oil to help prevent corrosion.
- ☑ Gears are permanently lubricated at the factory. Do not open the gearbox or dirt may enter.

## **ASSEMBLY INSTRUCTIONS**

### **STEP 1:**

**Remove spreader from carton and pull handle into position shown at right. Tighten wingnuts to secure.**

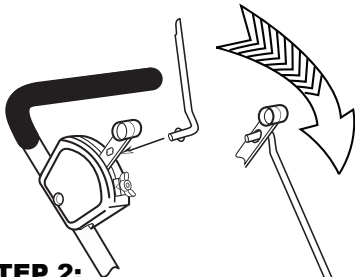

### **STEP 2:**

**Install Control Rod into handle as shown above.**

### **STEP 3:**

**Rotate forward.**

### **STEP 4:**

**Insert Control Rod into Pivot and secure with Hair Pin Clip.**

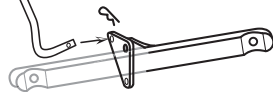

**Assembly is complete. Set the stop on the Control Assembly for the desired setting and your spreader is ready to operate.**

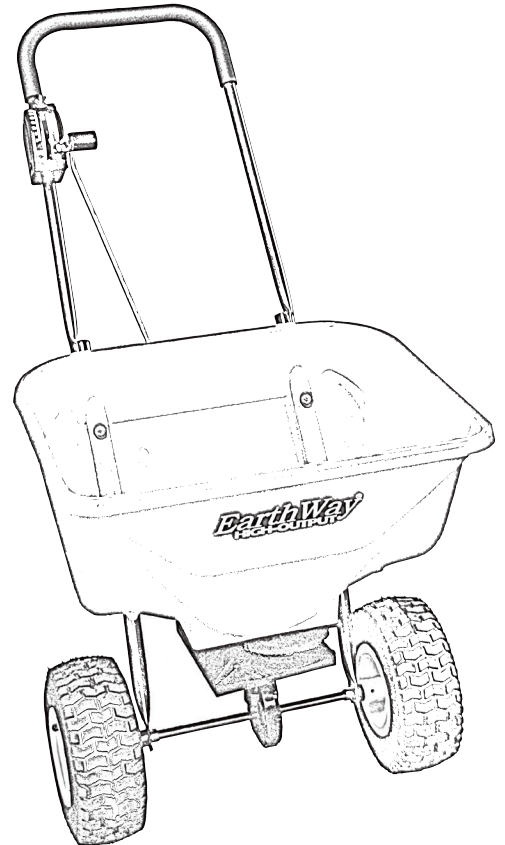

## **5-Year LIMITED WARRANTY**

EarthWay Products, Inc. warrants this product free of defects in original workmanship and materials for a period of 5-years to the end user with the original purchase receipt. If a manufacturing non-conformance is found, EarthWay Products, Inc. at its discretion will repair or replace the part(s) or product at no charge provided the failure is not the result of incorrect installation, mishandling, misuse, tampering, or normal wear and tear as determined by EarthWay. EarthWay at its discretion may require that the part(s) or product be returned along with the original purchase receipt at owners' expense for examination and compliance with the terms of this warranty. (Do not return any product without first receiving authorization from EarthWay Products, Inc.). To seek remedy under this warranty, contact EarthWay Products, Inc. at 574-848-7491, [techsupport@earthway.com](mailto:techsupport@earthway.com) or write to (EarthWay Products, Inc. P.O. Box 547 Bristol, Indiana 46507) and describe the nature of the manufacturing defect. **SPECIFIC LIMITATIONS:** This warranty covers only the part(s) or product; any labor charges associated with repair or replacement of non-conformances are specifically excluded. Due to the corrosive nature of most fertilizers and ice melt products, EarthWay Products, Inc. makes no warranty against and specifically excludes part(s) or product degradation or failure due to corrosion or its effects. Clean and dry your spreader thoroughly after each use, as a preventative measure, coat all metal parts with a light oil or silicon spray.

Part #52214PIR

EarthWay Products, Inc.

P.O. Box 547  
 Bristol, IN 46507  
 (574) 848-7491  
 or  
 800-294-0671

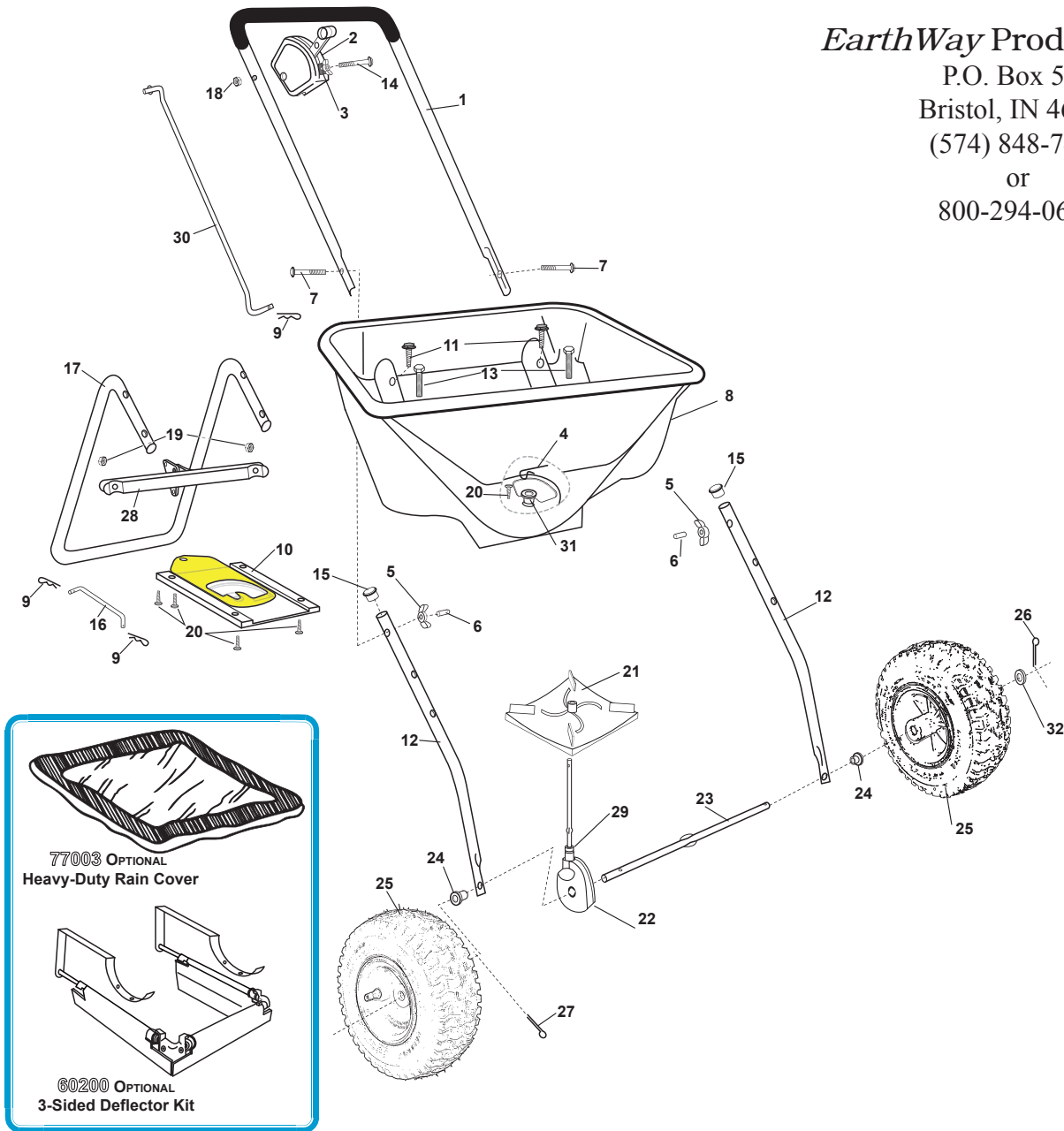

### 2040PiPlus Parts List

Key #	Part #	Description	Key #	Part #	Description	Key #	Part #	Description
1	60346	Upper Handle	12	25721	Lower Handle	23	23519	Axle
2	60524PIR	Control Assembly (2040PiPlus)	13	36213	1/4 x 2 1/2" HHCS	24	12197	Spacer Bearing
3	12222	Control Indicator	14	37108	1/4-20 x 1 3/4" Carriage Bolt	25	70149	9" Pneumatic Wheel
4	33117	Agitator	15	19132	7/8" Tube Plug	26	33106	1/8 x 3/4" Cotter Pin
5	60027	Wing Nut	16	41279	Pivot Rod (2040PiPlus)	27	33107	1/8 x 1-3/4" Cotter Pin
6	70142	Nut Protector	17	25720PIR	Stand	28	12295	Control Support Assembly
7	37116	1/4-20 X 2 1/4" Carriage Bolt	18	32100	1/4-20 Hex Nut	29	12206	Dust Cover
8	60250	Hopper Assembly (Ice Melt Bottom)	19	32110	1/4-20 Hex Lock-Nut	30	42287	Control Rod
9	33100	Hair Pin Clip (#213)	20	31122	#8 x 5/8" Screw	31	12259	Hopper Bushing
10	12230PIR	Shut Off Plate (Ice Melt 2040PiPlus)	21	12248	Impeller	32	34103	Washer 1" OD x 17/32" ID x 1/32"
11	31141	#14 x 3/4" Screw	22	60451	Gear Box Assembly			

**ATTENTION:**  
DO NOT USE FERTILIZER IN THE 2040PiPlus!

**ATTENTION:**  
N'EMPLOYEZ PAS L'ENGRAIS DANS LE 2040PiPlus!

**ATENCIÓN:**  
¡NO UTILICE EL FERTILIZANTE EN EL 2040PiPlus!